

VKS

VKSA

Stačiakampiai kanaliniai ventiliatoriai

Rectangular duct fans

Rechteckige Kanalventilatoren

Прямоугольные каналные вентиляторы

VKS

Stačiakampiai kanaliniai ventiliatoriai, skirti vėdinimo ir oro kondicionavimo sistemoms, montuojami į stačiakampių ortakių sistemą. Naudojami oro tiekimui ir šalinimui. Nenaudojami užteršto oro, agresyvių, sprogių dujų transportavimui. Kompaktiški, tyliai dirbantys, montuojami bet kokioje padėtyje, sparnuotė lengvai iškeliamą valymui.

Sparnuotė: į priekį lenktais sparneliais, cinkuoto plieno.

Variklis: išorinis rotorius, tiesioginė pavara, integruota termokontaktinė variklio apsauga, ilgai tarnaujantys nereikalaujantys priežiūros guoliai.

Korpusas: iš cinkuotos skardos.

VKSA

Garsinė izoliacija: akmens vata, 50mm storio.

Žemas triukšmo lygis.

VKS

Rectangular duct fans for ventilation and air conditioning systems, mounted into a system of rectangular air ducts. Used for the air supply or extract. Not suitable for polluted air, aggressive and explosive gases. Compact, with low noise level, mounted in any position, simple access to clean an impeller.

Impeller with forward curved blades made of galvanized steel.

Motor: external rotor, motor protection built-in thermal-contact, free-maintenance ball bearings.

Housing: made of galvanized steel.

VKSA

Sound insulation: rock wool, 50 mm thickness.

Low noise level.

VKS

Rechteckige Kanalventilatoren, die für Lüftungs- und Klimaanlagen bestimmt sind, werden in das System der rechteckigen Luftführungs Kanäle montiert. Sie werden für Zuluft und Abluft verwendet. Nicht geeignet für die Beförderung von verschmutzter Luft, aggressiven, explosiven Gasen. Kompakt, leise funktionierend, Montage in jeder beliebigen Stellung, das Flügelwerk ist leicht zur Reinigung herausnehmbar.

Laufgrad ist vorwärts gekrümmt, aus verzinktem Stahl.

Der Motor: Außenrotor, Direktantrieb, integrierter Thermokontakt-Motorschutz, dauerhafte, keine Pflege erfordernde Lager.

Das Gehäuse: aus verzinktem Blech.

VKSA

Schallsolation: Steinwolle, 50mm dick.

Niedriges Geräuschniveau.

VKS

Прямоугольные каналные вентиляторы для систем вентиляции и кондиционирования, устанавливаются в систему прямоугольных воздуховодов. Эксплуатируются в целях подачи и вытяжки воздуха. Не используются при транспортировке загрязнённого воздуха, агрессивных, взрывоопасных газов. Компактные, бесшумные, устанавливаются в любом положении, крыльчатка легко извлекается для чистки.

Крыльчатка: загнутые вперёд лопатки, оцинкованная сталь.

Двигатель: наружный ротор, прямая передача, встроенные термоконтакты двигателя, не требующие ухода подшипники с длительным сроком службы.

Корпус: оцинкованной жести.

VKSA

Звукоизоляция: минеральная вата толщиной 50 мм.

Низкий уровень шума

Accessories



LJ/E
LJ/PG
p. 183-184



SKS
p. 157



FDS
p. 151



EKS
p. 122



LG
p. 178

VKS

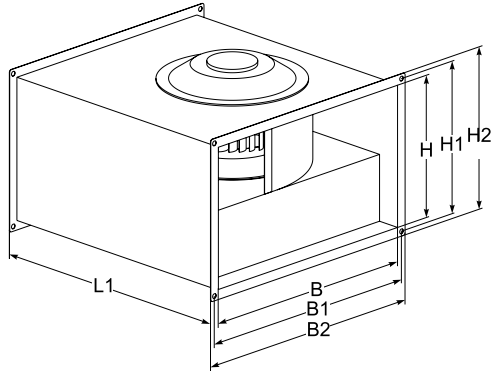

VKSA

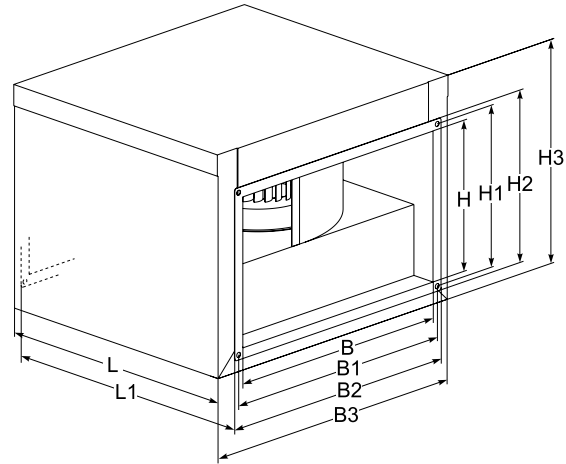

VKS

Type	Dimensions [mm]						
	B	B1	B2	H	H1	H2	L1
VKS 400x200	400	420	440	200	220	240	445
VKS 500x250	500	520	540	250	270	290	530
VKS 500x300	500	520	540	300	320	340	560
VKS 600x300	600	620	640	300	320	340	640
VKS 600x350	600	620	640	350	370	390	700
VKS 700x400	700	720	740	400	420	440	780
VKS 800x500	800	820	840	500	520	540	880
VKS 1000x500	1000	1020	1040	500	520	540	980

VKSA

Type	Dimensions [mm]									
	B	B1	B2	B3	H	H1	H2	H3	L	L1
VKSA 400x200	400	420	440	507	200	220	240	338	417	445
VKSA 500x250	500	520	540	605	250	270	290	393	502	530
VKSA 500x300	500	520	540	605	300	320	340	443	532	560
VKSA 600x300	600	620	640	705	300	320	340	443	612	640
VKSA 600x350	600	620	640	705	350	370	390	493	672	700
VKSA 700x400	700	720	740	811	400	420	440	562	752	780
VKSA 800x500	800	820	840	911	500	520	540	662	852	880
VKSA 1000x500	1000	1020	1040	1110	500	520	540	662	952	980

Accessories



TGRV
p. 143



TGRT
p. 144



MTY
p. 146

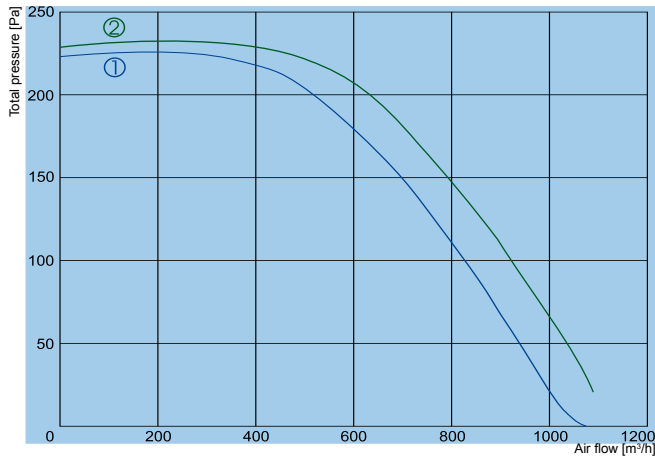

- ① — VKS/VKSA 400x200-4 L1
- ② — VKS/VKSA 400x200-4 L3

		400x200-4 L1	400x200-4 L3
Voltage/Frequency	[V/Hz]	230/50	400/50
Power consumption	[kW]	0,36	0,31
Current	[A]	1,80	0,51
Speed	[min ⁻¹]	1180	1230
Max. airflow	[m ³ /h]	1079	1090
Max. air temperature	[°C]	40	70
Total sound pressure level at 1 m	[dBA]	68 / 62	66 / 60
Speed controller		TGRV1,5 / MTY2	TGRT1
Weight	[kg]	14 / 21	14 / 21
Wiring diagram		No. 1	No. 2
Protection class:	motor	IP-54	IP-54
	terminal box	IP-55	IP-55

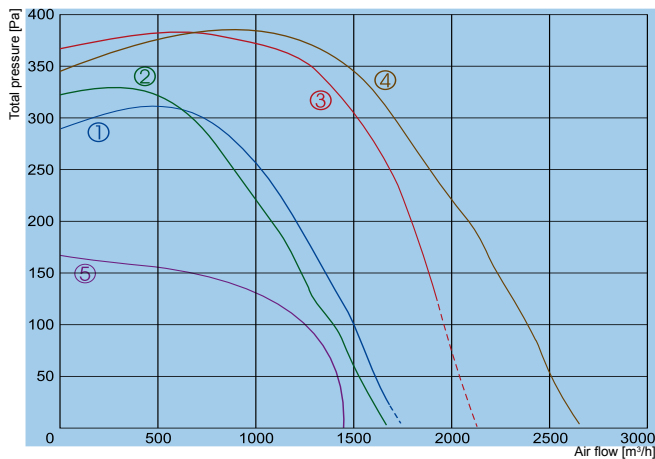

- ① — VKS/VKSA 500x250-4 L1
- ② — VKS/VKSA 500x250-4 L3
- ③ — VKS/VKSA 500x300-4 L1
- ④ — VKS/VKSA 500x300-4 L3
- ⑤ — VKS/VKSA 500x300-6 L1

		500x250-4 L1	500x250-4 L3	500x300-4 L1	500x300-4 L3	500x300-6 L1
Voltage/Frequency	[V/Hz]	230/50	400/50	230/50	400/50	230/50
Power consumption	[kW]	0,51	0,56	0,69	0,93	0,29
Current	[A]	2,3	0,95	3,0	1,90	1,47
Speed	[min ⁻¹]	1250	1270	1190	1380	680
Max. airflow	[m ³ /h]	1651	1665	1883	2647	1400
Max. air temperature	[°C]	40	40	40	50	50
Total sound pressure level at 1 m	[dBA]	73 / 67	76 / 70	73 / 67	80 / 74	48 / 38
Speed controller		TGRV3 / MTY4	TGRT1	TGRV4 / MTY4	TGRT2	TGRV 3
Weight	[kg]	16 / 23	16 / 23	21 / 28	21 / 28	21 / 28
Wiring diagram		No. 1	No. 2	No. 1	No. 2	No. 1
Protection class:	motor	IP-54	IP-54	IP-54	IP-54	IP-54
	terminal box	IP-55	IP-55	IP-55	IP-55	IP-55

The fan characteristic curves were determined in accordance with DIN 24163 resp. ISO 5801. The sound power levels were determined in accordance with DIN 45635 resp. ISO 3744 at a distance of 1 m from the fan

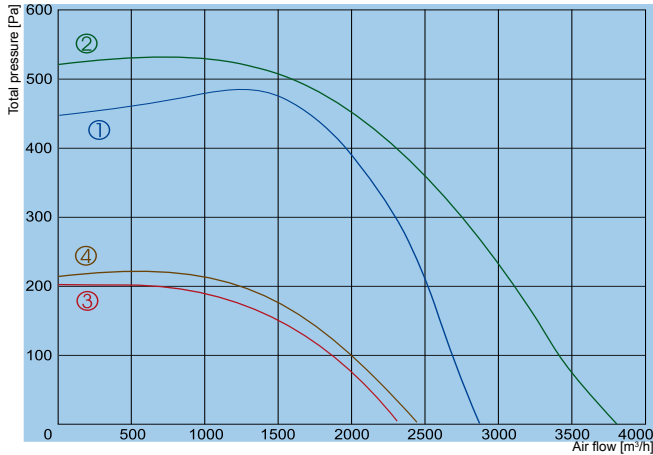

- ① — VKS/VKSA 600x300-4 L1
- ② — VKS/VKSA 600x300-4 L3
- ③ — VKS/VKSA 600x300-6 L1
- ④ — VKS/VKSA 600x300-6 L3

		600x300-4 L1	600x300-4 L3	600x300-6 L1	600x300-6 L3
Voltage/Frequency	[V/Hz]	230/50	400/50	230/50	400/50
Power consumption	[kW]	1,15	1,50	0,47	0,42
Current	[A]	5,10	2,60	2,21	0,86
Speed	[min ⁻¹]	1210	1310	900	835
Max. airflow	[m³/h]	2882	3800	2300	2450
Max. air temperature	[°C]	40	40	70	40
Total sound pressure level at 1 m	[dBA]	74 / 68	81 / 75	55 / 45	49 / 39
Speed controller		TGRV7	TGRT3	TGRV 3	TGRT2
Weight	[kg]	29 / 37	29 / 37	31/38	25/32
Wiring diagram		No. 1	No. 2	No. 1	No. 2
Protection class:	motor	IP-54	IP-54	IP-54	IP-54
	terminal box	IP-55	IP-55	IP-55	IP-55

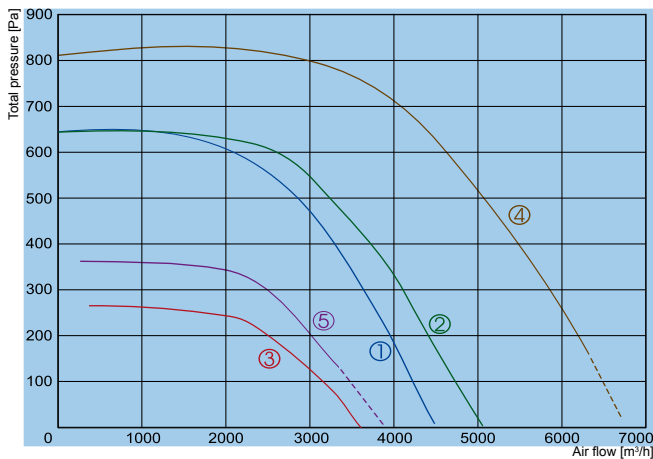

- ① — VKS/VKSA 600x350-4 L1
- ② — VKS/VKSA 600x350-4 L3
- ③ — VKS/VKSA 600x350-6 L3
- ④ — VKS/VKSA 700x400-4 L3
- ⑤ — VKS/VKSA 700x400-6 L3

		600x350-4 L1	600x350-4 L3	600x350-6 L3	700x400-4 L3	700x400-6 L3
Voltage/Frequency	[V/Hz]	230/50	400/50	400/50	400/50	400/50
Power consumption	[kW]	2,40	2,50	0,90	3,70	1,1
Current	[A]	11,0	4,10	1,8	6,0	2,0
Speed	[min ⁻¹]	1340	1300	750	1320	790
Max. airflow	[m³/h]	4478	5056	3600	6300	3250
Max. air temperature	[°C]	40	40	40	40	40
Total sound pressure level at 1 m	[dBA]	84 / 78	82 / 76	71 / 61	87 / 81	67 / 57
Speed controller		TGRV14	TGRT5	TGRT2	TGRT7	TGRT3
Weight	[kg]	36 / 47	36 / 47	24/31	62 / 78	32 / 39
Wiring diagram		No. 1	No. 2	No. 2	No. 2	No. 2
Protection class:	motor	IP-54	IP-54	IP-54	IP-54	IP-54
	terminal box	IP-55	IP-55	IP-55	IP-55	IP-55

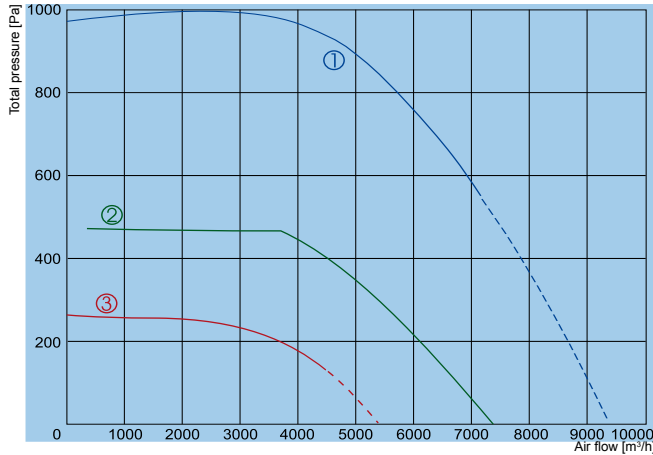

- ① **VKS/VKSA 800x500-4 L3**
- ② **VKS/VKSA 800x500-6 L3**
- ③ **VKS/VKSA 800x500-8 L3**

		800x500-4 L3	800x500-6 L3	800x500-8 L3
Voltage/Frequency	[V/Hz]	400/50	400/50	400/50
Power consumption	[kW]	5,0	2,7	1,14
Current	[A]	8,10	4,9	2,4
Speed	[min ⁻¹]	1330	830	555
Max. airflow	[m ³ /h]	7120	7250	4500
Max. air temperature	[°C]	40	50	40
Total sound pressure level at 1 m	[dBA]	89 / 83	77 / 67	59 / 69
Speed controller		TGRT11	TGRT5	TGRT3
Weight	[kg]	85 / 99	52 / 59	63 / 70
Wiring diagram		No. 2	No. 2	No. 2
Protection class:	motor	IP-54	IP-54	IP-54
	terminal box	IP-55	IP-55	IP-55

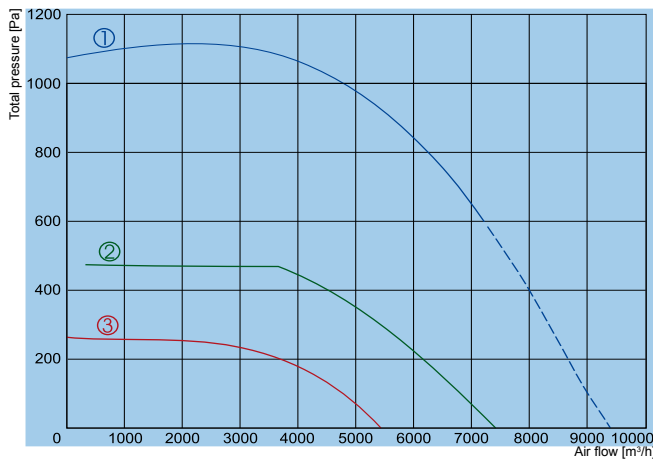

- ① **VKS/VKSA 1000x500-4 L3**
- ② **VKS/VKSA 1000x500-6 L3**
- ③ **VKS/VKSA 1000x500-8 L3**

		1000x500-4 L3	1000x500-6 L3	1000x500-8 L3
Voltage/Frequency	[V/Hz]	400/50	400/50	400/50
Power consumption	[kW]	5,0	2,7	1,14
Current	[A]	8,10	4,9	2,40
Speed	[min ⁻¹]	1330	830	555
Max. airflow	[m ³ /h]	7200	7200	5380
Max. air temperature	[°C]	40	50	40
Total sound pressure level at 1 m	[dBA]	89 / 83	77 / 67	59 / 49
Speed controller		TGRT11	TGRT5	TGRT3
Weight	[kg]	88 / 111	53 / 60	64 / 71
Wiring diagram		No. 2	No. 2	No. 2
Protection class:	motor	IP-54	IP-54	IP-54
	terminal box	IP-55	IP-55	IP-55

The fan characteristic curves were determined in accordance with DIN 24163 resp. ISO 5801. The sound power levels were determined in accordance with DIN 45635 resp. ISO 3744 at a distance of 1 m from the fan

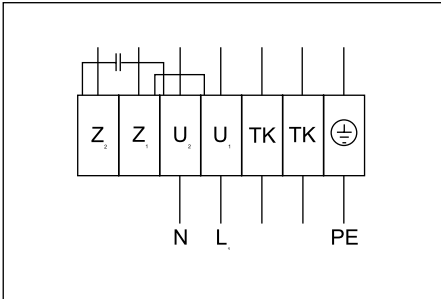

Wiring diagram No. 1 (1~230V)

U₁ = brown
 U₂ = blue
 Z₁ = black
 Z₂ = orange
 TK = white

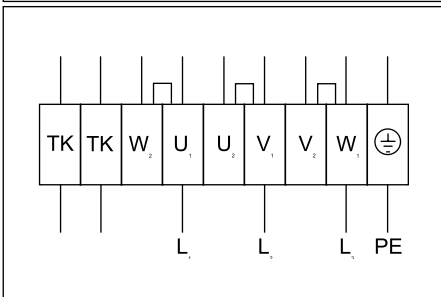

Wiring diagram No. 2 (Δ - 3~400V)

U₁ = brown
 U₂ = red
 V₁ = blue
 V₂ = grey
 W₁ = black
 W₂ = orange
 TK = white

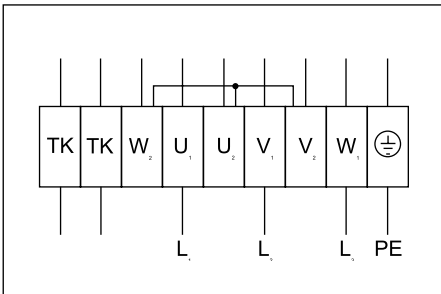

Wiring diagram No. 2 (Y - 3~400V)

U₁ = brown
 U₂ = red
 V₁ = blue
 V₂ = grey
 W₁ = black
 W₂ = orange
 TK = white